

Aventuras em
ORBE DE LIBRA

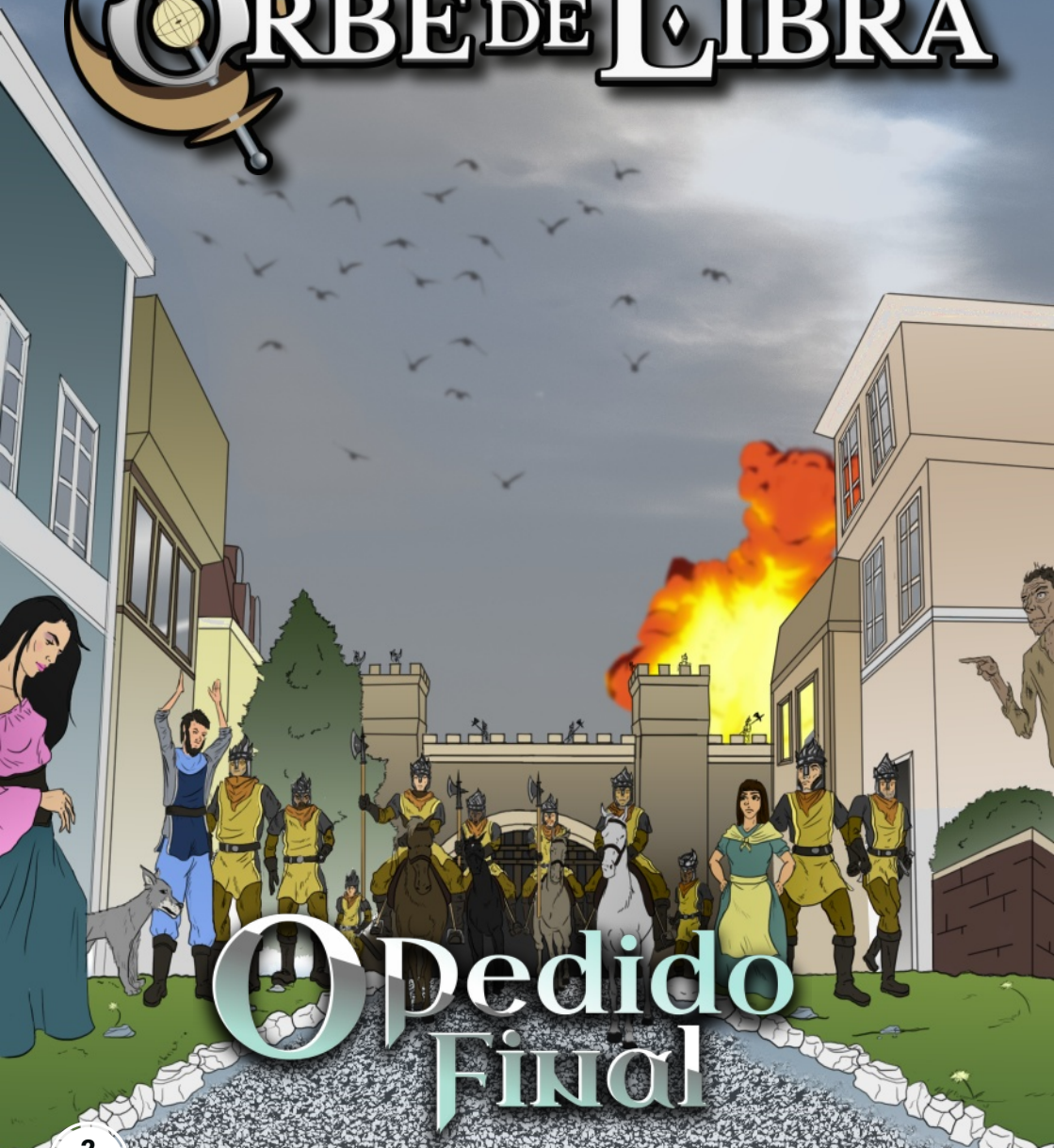

O Pedido Final

2
Mar/20

VINÍCIUS PERES • FERNANDO MOREIRA

ROTEIRO
VINÍCIUS PERES

DESENHO & CORES
FERNANDO MOREIRA

CAPA
FERNANDO MOREIRA

REVISÃO
VINÍCIUS PERES

DIAGRAMAÇÃO
DIEGO "ALFACE" LOIOLA

AGRADECIMENTOS

ANDERSON "BILICO" JESUS, BRUNO "FRANGO" FERNANDES, DANILO MOTA, JAIMES "BERSERK", JEAN "JAGUAR" RICIERI E PAULO PERES
PELOS DIAS E HORAS À FIO DE JOGATINA.

APOIO

 **TEATRO DE MESA**

www.teatrodemesa.com.br

HQ baseada em aventuras vividas no cenário de campanha **Orbe de Libra**® de Vinícius Peres, sendo uma livre adaptação dos resumos das sessões de jogo de uma campanha de

RPG



A aventura começara e o caminho a ser percorrido seria longo e cheio de surpresas.

Não conheciam as terras ao nordeste e nem os acontecimentos recentes que assolavam seus povos.

Mas seus intintos diziam que grandes acontecimentos os aguardavam.

CAPÍTULO 2

FRONTEIRAS FECHADAS



*P*assados mais alguns dias de viagem avistaram um vilarejo...

...e decidiram parar para descansar e se alimentar.



*P*oderiam também se infomar sobre os acontecimentos no nordeste.



ACHEI UM LUGAR.

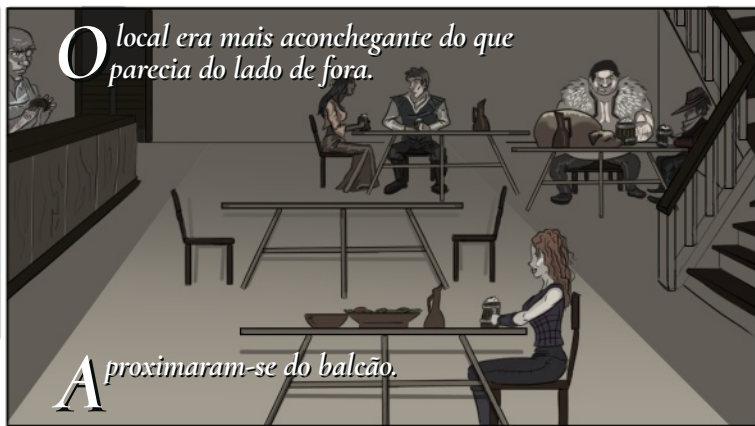

O local era mais acolhedor do que parecia do lado de fora.

*A*proximaram-se do balcão.



PRAZER, BALDO.
QUEREMOS CERVEJA E
COMIDA.

VIAJANTES? HUNF... ME
CHAMO OTONIO, VÃO
QUERER O QUÊ?



MUITA
CERVEJA!



QUEREMOS TAMBÉM
SUPRIMENTOS DE VIAGENS, PARA
DOIS. E, À PROPÓSITO, O SENHOR
JÁ OUVIU FALAR EM "OLHOS DE
MEL"?

SOU KORIN
PAZVERDEJANTE E O
BEBERRÃO APRESSADO
É ARTURIO.



PRECISAMOS MUITO
DE INFORMAÇÕES.



ME PARECE QUE NÃO
É SÒ O GRANDÃO O
APRESSADO...

A pós muitas canecas e pratos, ganharam a confiança do rabugento Otonio.

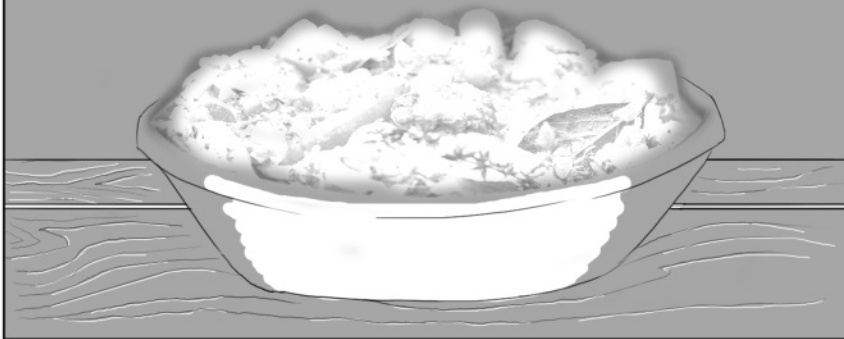
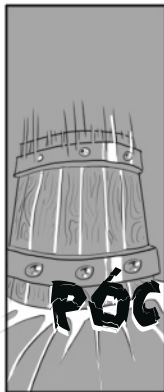

Otonio indicou onde comprar suprimentos...



...um amigo de longa data.

Baldo negociou e comprou o bastante para alguns dias.

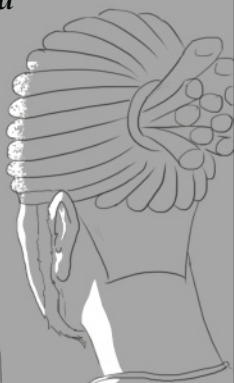

Também citou a luva...

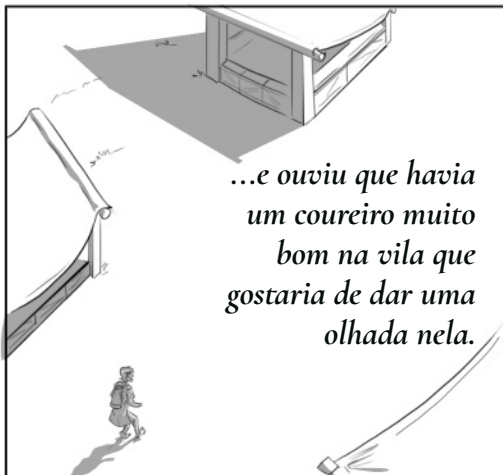

...e ouviu que havia um coureiro muito bom na vila que gostaria de dar uma olhada nela.



HUMM...



AVISAREI OS RAPAZES.





QUERO LEVAR VOCÊS
A UM LUGAR.



FINALMENTE. VOCÊ
TINHA SUMIDO!

LEVANTA DAÍ, 'FRESCO',
VAMOS SEGUIR O
PEQUENINO.

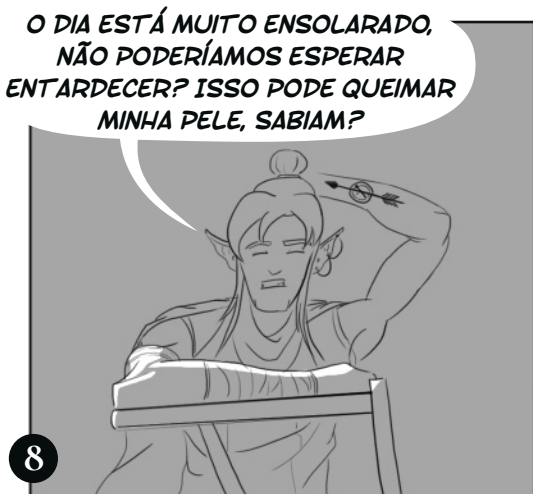

O DIA ESTÁ MUITO ENSOLARADO,
NÃO PODERÍAMOS ESPERAR
ENTARDECER? ISSO PODE QUEIMAR
MINHA PELE, SABIAM?



FALA SÉRIO...

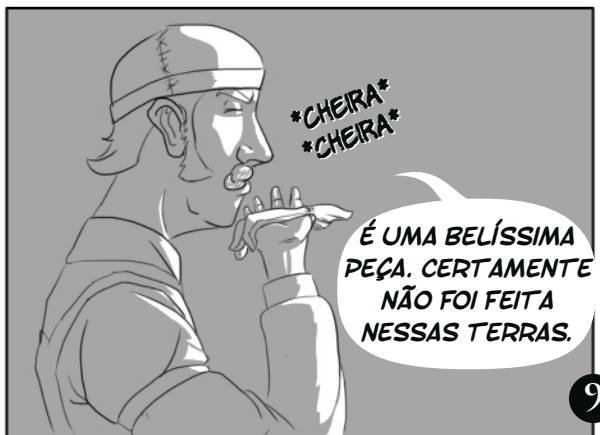
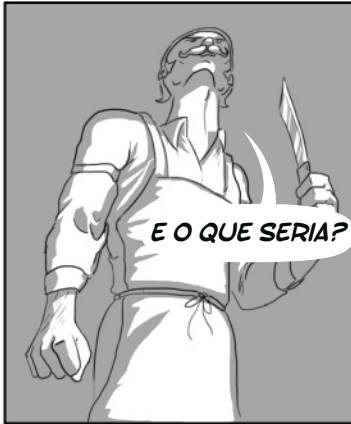

ESSE COURO VEM DE
MUITO LONGE...



...DE TOROS.

MAS VOCÊ ACEITA O
TRABALHO?



UMA RÉPLICA?
HUM...



POSSO TENTAR...

ME DÊM ALGUMAS
HORAS...



UAU!

INCRÍVEL!

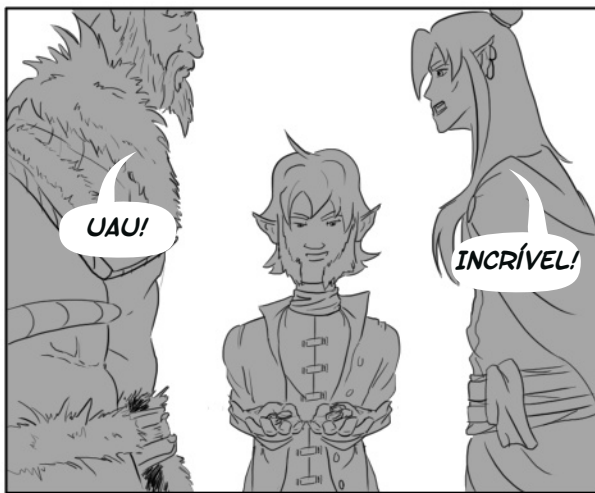

Não era perfeito,
mas havia
ficado excelente.

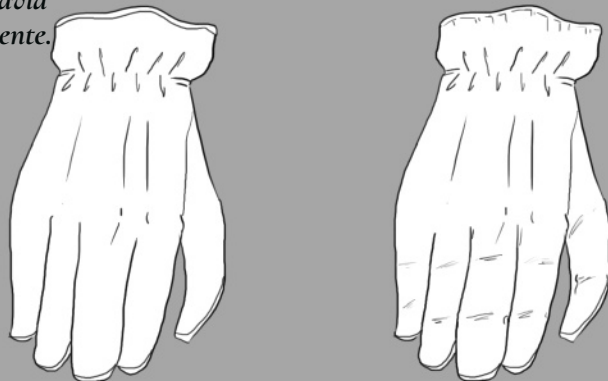

Pagaram o
combinado e
aproveitaram para
perguntar mais sobre a
origem da luva original.

VALENTES
GUERREIROS E
GRANDES
PASTORES.

TOROS PERTENCE ÀS
TERRAS DO NORTE.

ESSE COURO
DEVE TER
SIDO TRAZIDO
PELO MAR.

PELO PORTO
da Paz NA
ATUAL Tropel.

SIM, OS HOMENS USAVAM
FREQUENTEMENTE O PORTO PARA
CHEGAR ATÉ TOROS E OUTROS
REINOS PRÓXIMOS.

Guardaluz...
Tropel...

BEM, PRECISAMOS IR.
OBRIGADO, SENHOR,
PASSAR BEM!

Korin e Baldo
seguiram
rapidamente os passos de
Arturio enquanto
olhavam o mapa que
carregavam.



Tentavam
ligar tudo
que vinham
escutando
recentemente.

Ao raiar do dia seguinte partiram novamente. O destino ainda era o nordeste.

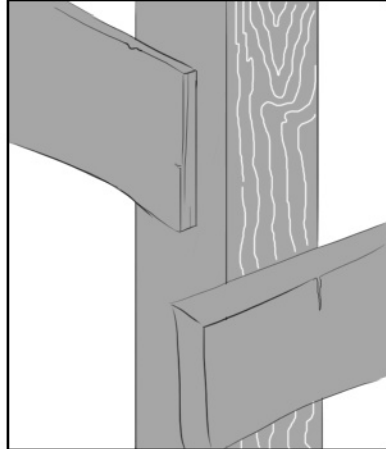

Marcações no caminho indicavam que estavam próximos de onde queriam chegar...

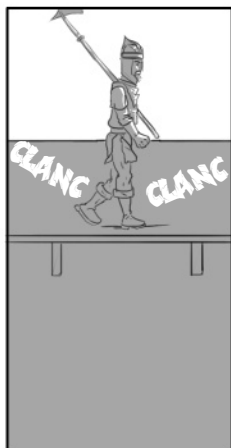
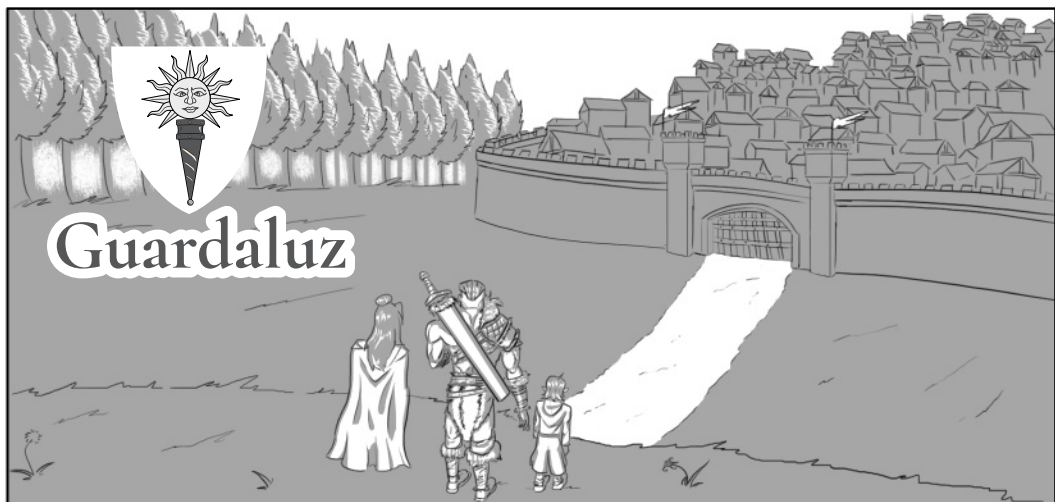

**SOLDADOS! ATENÇÃO!
ANDARILHOS SE
APROXIMAM DO
PORTÃO SUL!**

AHNNN!

**DEVO ACERTÁ-LOS?
ESTÃO NA MIRA.**

AHNNN!

Antes de entrar foram interrogados junto com outros que também recém chegavam.



NÃO! ESPEREM CHEGAR ATÉ OS PORTÕES. TALVEZ NÃO SEJAM INIMIGOS.

NEM ME FALE. ELAS PARECIAM PRECUPADOS.



QUE CLIMA TENSO.



ESSE É O CHEIRO DA GUERRA. SINTO NO AR.



TENHO UMA IDEIA, VAMOS ATÉ A BIBLIOTECA LOCAL.

MALDITOS LIVROS!

CERTAMENTE TEREI ACESSO AOS REGISTROS RECENTES.



No caminho até a biblioteca notaram os ares de preocupação e angústia que pairavam na cidade.

Uma extensa área repleta de tomos e pergaminhos.

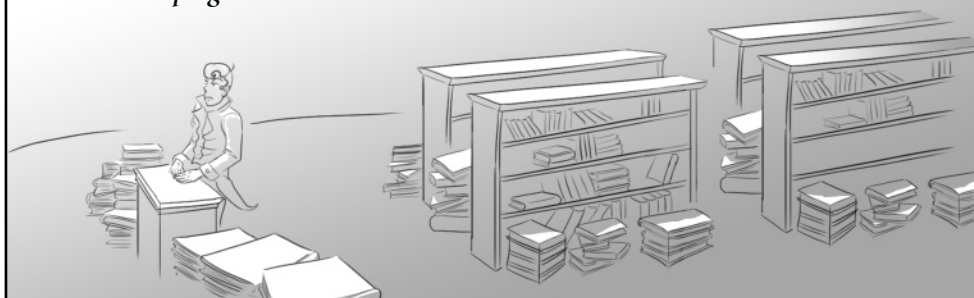

DEIXA EU DAR UMA OLHADA NISSO...

...E NISSO AQUI...

PERÁÍ, ESSE FASCÍCULO EU NUNCA TINHA VISTO.







ORELHUDO, NÃO BANQUE O ESPERTINHO E NÃO ENTRE ONDE NÃO FOR PERMITIDO. NÃO QUERO PROBLEMAS, ESSE TRABALHO PAGA BEM.



CLARO, GRANDÍSSIMO ANÃO, DIGO, MAGNÍFICO ANÃO. SEREI BREVE.

GGGRRR!

Mas Korin não seria tão obediente...

Textos para Revisão

...e num piscar de olhos onde Dworak vacilou por instantes...

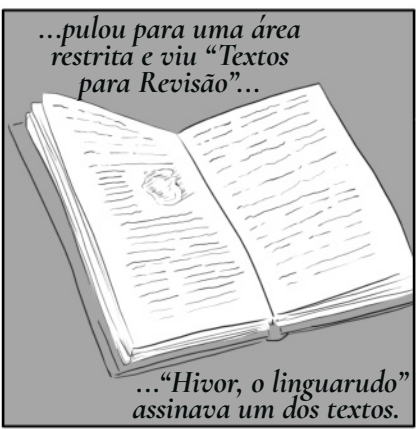

...pulou para uma área restrita e viu "Textos para Revisão"...

...“Hivor, o linguarudo” assinava um dos textos.

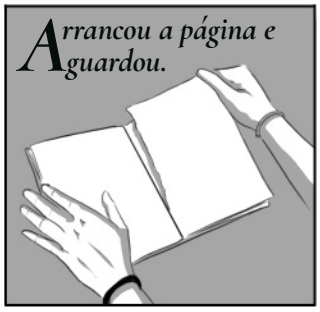
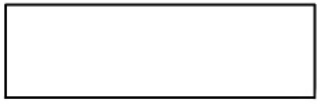

Arrancou a página e guardou.



Ao ver que um outro guarda o observava...



...saiu antes de ser pego.



AVISE OS MERCENÁRIOS PARA SEGUIREM ESSE PASPALHO, ELE ME PARECEU MUITO SUSPEITO. PODE SER UM ESPÍÃO 'DELES'!



Os "mercenários" eram Kai, Szasslack e o próprio Dworak. Baldo percebendo o que estava ocorrendo se antecipou.



SENHORES, BOA TARDE! PERCEBO QUE TAMBÉM NÃO SÃO NATIVOS.



PODEM NOS CONTAR O QUE ACONTECE POR ESSAS TERRAS?



SE CONTAREM O QUE SEU AMIGO CURIOSO "QUERIA" NA BIBLIOTECA, SIM



ERR, EU NÃO SEI DO QUE VOCÊ ESTÁ FALANDO, MAS PODEMOS SENTAR TODOS E CONVERSAR. O QUE ACHAM?



ÓTIMA IDEIA!



Marcaram o encontro ao cair da noite em uma estalagem.



MAS QUE ESPELUNCA! ISSO É UM PULGUEIRO.

NÃO RECLAME, AO MENOS NÃO CHAMAREMOS MUITA ATENÇÃO.

VOCÊ DORMIRIA FELIZ MESMO EM UMA CAMA DE ESPINHOS, ARTURIO.

PRA MIM ESTÁ MAIS DO QUE BOM!



NÃO HAVIA OUTRA SAÍDA, TALVEZ NOS AJUDEM COM O QUE PODEM NOS DIZER.

ESTOU TEMEROSO COM ESSA CONVERSA COM OS TRÊS MERCENÁRIOS



ESTÃO CERTOS DISSO?

É UM RISCO NECESSÁRIO...

VAMOS, NÃO TEMOS TEMPO À PERDER!

OU PODEMOS QUEBRAR OS OSSOS DELES E IR EMBORA...



PRECISAMOS DE RESPOSTAS!



Guerreiro errante



Oh céus! Estou andando há horas, melhor seria estar numa taverna.

CAVERNA?!
ÓTIMA IDEIA.



Não, não! Eu disse "TAVERNA"

Uau!

Ao menos terei sombra.



PERAÍ, DEIXE SÓ EU ROLAR UM DZO AQUI.

PUTS! DEU RUIM

Oqueeeee!?





O Pedido Final

PRÓXIMO CAPÍTULO:
CONTATOS NO Submundo

 ORBE DE LIBRA

